



SPECIFICATION

Fully welded construction finished in non-slip satin, polished or powder-coated surfaces to promote durability and reliability. Designed for the safety, security and convenience of the physically disabled. Strong Ø75 fixing flanges. Easy to install on most building surfaces. Grab Rails provide flush mounting flanges which are fully welded to the tube ends. This results in a single structural unit that is designed to give maximum strength, security and user confidence to support greater loads. Attractive stainless steel cover plates are available for most units, to conceal the flange and fixings.

Grab Rail GR01/40 shall be Model No. GR01/40 (left hand model shown) as supplied by JD MacDonald.

OPTIONS

JD MacDonald can supply special Grab Rails to satisfy any unique application (POA).

FINISH

Manufactured from austenitic 18/8 grade 304 stainless steel.

RECOMMENDED INSTALLATION

To comply with Australian Standards AS 1428.1, grab rails must be fastened a minimum distance of 800mm from the floor, with 600mm of clear space above the rail and to withstand a force of 1100N at any point from any direction.

WARRANTY

Grab rail products distributed by JD MacDonald are guaranteed to be free from defective materials and workmanship for 12 months from the date of purchase, subject to product being installed and maintained in accordance with the Installation and Operating instructions supplied. Products returned to JD MacDonald under this warranty will be, at the option of the company, repaired or replaced at no charge to the purchaser.

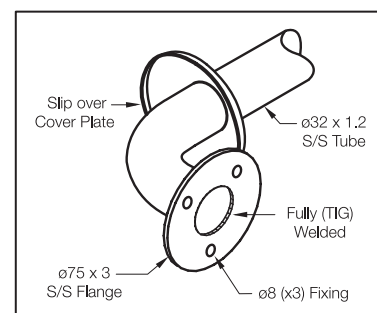
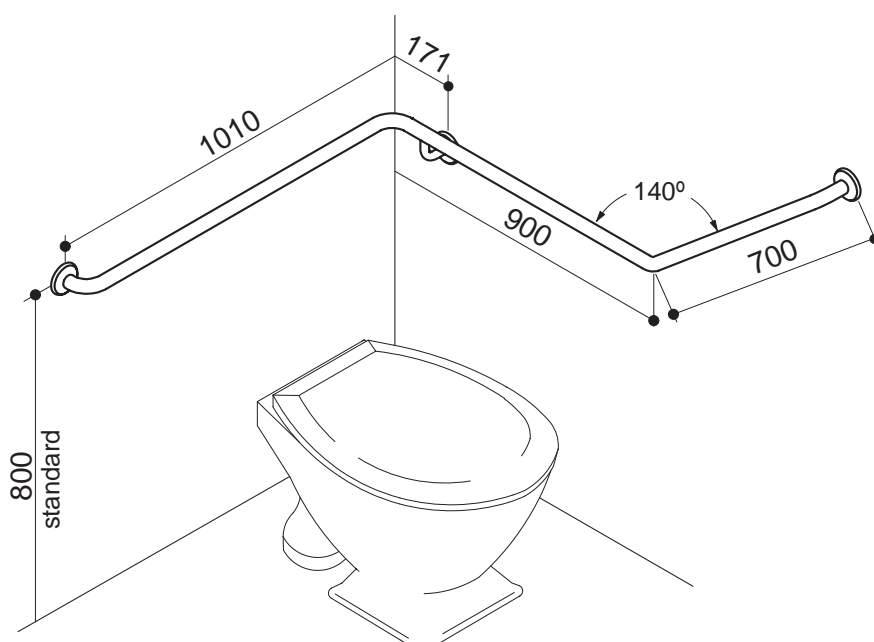

strength from welded construction

Illustrations and descriptions included here are applicable to production as of the date of this leaflet. JD MacDonald reserves the right and does from time to time make changes and improvements in designs and dimensions.