



## FEATURES

- Priced for budget-sensitive projects
- 113kg static load capacity when installed properly; tested to 177kg.
- Easy-clean, high-density polyethylene which inhibits bacterial growth
- Compact, slim profile protruding 120 mm from wall
- Vertical design provides easy-access for parents and carers
- Child protection strap (webbed polypropylene) with snap on fasteners for safety and security
- Convenient bag hooks on both sides
- Dual molded-in liner dispensers hold approx 50 liners each (liners sold separately)
- Pneumatic gas spring mechanism for smooth, safe and effortless opening and closing
- Easy to read labels illustrate proper use and safety information with universal instruction graphics
- Simple and quick to install with step-by-step instructions plus all mounting hardware
- Mounting caps provided to conceal screw heads for a quality finish

## OPTIONS

Box of 500 liners (Order Part No: LCR)

Replacement safety belt assembly (Order Part No: B004)

## WARRANTY

All baby change stations distributed by JD MacDonald are guaranteed to be free from defective materials and workmanship for 5 years from the date of purchase subject to the product being installed and maintained in accordance with the Installation and Operating Instructions supplied.

## VANDALISM PROTECTION

Should any baby change station distributed by JD MacDonald be vandalized rendering the unit unsafe or unusable in the 5 year period from the date of purchase, JD MacDonald will provide a \$100 discount off the retail price when a replacement unit is purchased by the owner, through JD MacDonald.

## PRODUCT LIABILITY INSURANCE

A \$10 million general product liability insurance policy is maintained on all baby change stations.

## PREMIUM MODEL VERTICAL UNIT DUE FOR RELEASE IN 2008

## RECOMMENDED BLOCKING

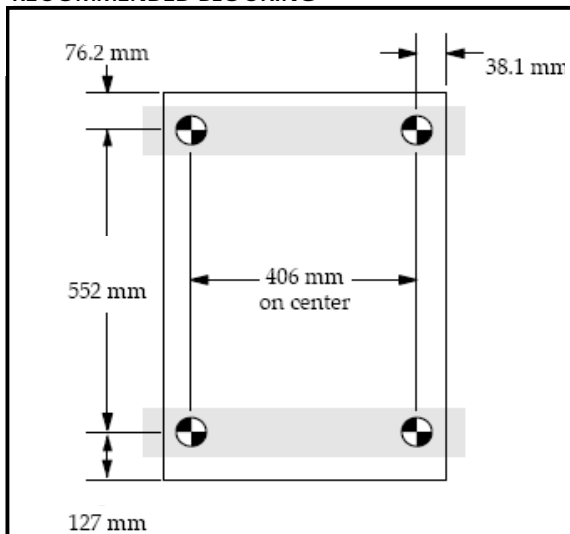

## SHORT SPECIFICATION

Polyethylene Baby Change Stations:

1. Acceptable product: Model BCV-ECO
2. Characteristics:
  - a. Type: Molded high-density polyethylene (HDPE) body
  - b. Adjustable child protection strap
  - c. Overall dimensions: 877mmH x 496mmW x 120mmD